

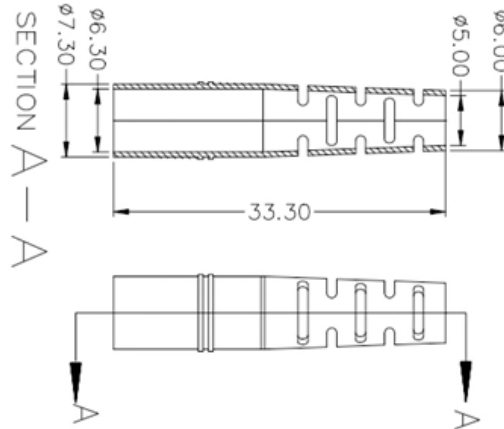

ZTP Thermal & Power

Compliant Home Electrical Distribution Box





Overview

In this guide, we'll break down everything you need to know to install a distribution box correctly and confidently. Choose the right box based on environment (indoor/outdoor), load capacity, and durability. A Distribution Box serves as a fully enclosed, highly robust mechanical housing designed specifically to route electrical power safely from the main supply line to individual subsidiary circuits. It distinguishes its primary purpose by providing centralized, secure housing for sensitive protective. By combining industrial-grade components, structured load management, and flexible electrical enclosure design, E-abel provides B2B partners with compliant, scalable, and future-ready low-voltage distribution panels for residential communities worldwide. In modern electrical systems, cable distribution boxes (also known as electrical distribution boxes or distribution boxes) play a crucial role as the key hub for managing, distributing, and protecting circuits.



Compliant Home Electrical Distribution Box

What Is a Distribution Box?

A distribution box is a device that, as the name suggests, is designed to distribute electrical power. It takes the electrical power from the main power

[Read More](#)

Distribution Box and Selection Guide

Distribution Box Selection Guide This guide provides information on how to select the appropriate Distribution Box for Electric project. If you have any

[Read More](#)



Power Distribution Boxes Explained Simply

Discover the essentials of a Power Distribution Box--how it works, key types, benefits, and tips to ensure safe, efficient electrical power management.

[Read More](#)

Distribution box

Whether in your own home, in a rented apartment or in a business, the distribution box is a central element of every electrical system. Despite this, it often ekes out an inconspicuous existence in the

[Read More](#)

Requirements And Specifications For Installation Of

The installation requirements and specifications of Distribution box involve many aspects, including site selection, fixing method, wiring specifications

[Read More](#)



How to Install a Distribution Box--A Comprehensive

Whether you are an electrical contractor or a construction brigade, knowing how to properly and safely install distribution boxes is the basis of

[Read More](#)

Understanding Distribution Boxes: Your Guide to Power

Every single type of these power distribution boxes serve to regulate electricity management systems safeguarding the structure against unauthorized

[Read More](#)

How to Choose a Home Distribution Box - Expert Guide

Learn how to choose the right home distribution box with our expert guide. Compare



circuit capacity, IP ratings, breaker types & avoid common mistakes.

[Read More](#)

Customized Residential Power Distribution Boxes for Community

Explore how E-abel residential power distribution boxes solve overcurrent risks, electrical leakage, and phase imbalance in modern communities. Learn how customizable low-voltage

[Read More](#)

Electrical Distribution Boxes for Power Distribution

The Wieland distribution boxes accommodate all required components of the electrical installation as well as building automation on a project-specific basis.

[Read More](#)



The Importance of Distribution Boxes in Electrical Systems

Learn more about how distribution boxes play a critical role in the safe and efficient operation of electrical systems.

[Read More](#)

Amazon : Champion Power Equipment Pro Grade

Buy Champion Power Equipment Pro Grade OSHA Compliant Power Distribution Box, 50-Amp Twist Lock Inlet, Six 120V GFCI Duplexes, One 120/240V 30A

[Read More](#)

How to Choose a House Distribution Box , CHINT global

A well-chosen distribution box ensures the safety and efficiency of your household electrical system. This article guides you through selecting a



[Read More](#)

How to Choose the Right Distribution Box for Your Home or Workshop

Learn how to choose the right distribution box for your home or workshop. Discover sizing rules, component selection, and strict electrical safety standards.

[Read More](#)

Guardians of Safety: A Comprehensive Guide to

Stringent electrical codes and regulations govern the design and installation of electrical boxes. This commitment to compliance ensures that power distribution

[Read More](#)



What is an Electrical Distribution Box? A

When it comes to electrical safety, every building -- whether it's a cozy home or a sprawling factory -- needs a secure system to manage and

[Read More](#)

Top 10 Smart Home Distribution Boxes for Modern Homes

Compare the top 10 smart home distribution boxes for modern homes. Find the best home distribution box for safety, energy savings, and smart control.

[Read More](#)

Ultimate Guide To Distribution Boxes Db Boxes Types

This ultimate guide explains what a distribution box does, its internal components, common types, real-world applications, and how to select the right DB Box for

[Read More](#)



Compliant Custom Power Distribution Box with Saudi Electrical

When you choose our custom power distribution boxes, you're getting more than a product--you're getting: Compliance You Can Trust: Engineered to meet and exceed Saudi electrical

[Read More](#)

Amazon .uk: Electrical Distribution Box

Amazon .uk: electrical distribution box Check each product page for other buying options. Price and other details may vary based on product size and colour.

[Read More](#)

How to Install a Cable Distribution Box Safely and



Reliable cable distribution boxes ensure safe, efficient power management for residential, commercial, and industrial systems. Learn

[Read More](#)

Distribution Box Installation: A Complete Guide to Safe

The distribution box, often referred to as a breaker box, fuse box, or electrical panel, is a critical component of any electrical system. It acts as the central hub for

[Read More](#)

A comprehensive understanding of distribution box

? Introduction Distribution boxes are at the heart of safe and organized electrical systems--whether in residential, commercial, or industrial settings. But

[Read More](#)



DB BOX(Electrical Distribution Box): Everything You

Learn everything you need to know about the Electrical Distribution Box (DB Box). Explore types, materials, installation tips, etc.

[Read More](#)

How to Choose a House Distribution Box

Choosing the house distribution box that best fits your home is important for your safety and the efficiency of your electrical system. It facilitates the flow of electricity, guards appliances, and

[Read More](#)

Contact Us

For datasheets, pricing, or custom data center infrastructure solutions, please visit:
<https://www.zeldaterblanchephotography.co.za>