

# Elevated Molecular Bridge

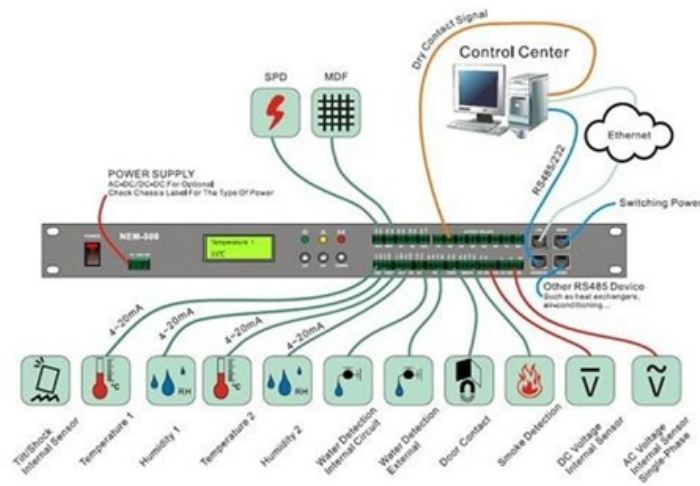



## Elevated Molecular Bridge

---

### **Bridging molecular and cellular neuroscience with proximity labeling**

As PL technologies continue to evolve, they bridge molecular and cellular neuroscience, offering a useful framework for unraveling the complexity of brain networks.

[Read More](#)

### **Oriented molecular bridge at the buried interface enables cesium-lead**

In this study, we propose a functional molecular bridge, constructed by integrating 3,4-thiophenedicarboxylic acid (TDDA) at the interface between the perovskite and TiO<sub>2</sub> layer, to

[Read More](#)



## **Molecular bridge-mediated ultralow-power gas sensing**

We report the electrical detection of captured gases through measurement of the quantum tunneling characteristics of gas-mediated molecular junctions formed across nanogaps. The

[Read More](#)

## **Molecular Bridging at Buried Interface Enables Efficient**

The regulation of buried interface is crucial for high-performance wide-bandgap perovskite solar cells (PSCs), which can influence the interfacial defects, the charge transport, and the

[Read More](#)

## **Tailoring pyridine bridged chalcogen-concave molecules for defects**



Tailoring pyridine-bridged chalcogen-concave molecules for defect passivation enables efficient and stable perovskite solar cells Muhammad Azam, Yao Ma, Boxue Zhang, Xiangfeng Shao,

[Read More](#)

## **Small molecule bridged MOF-802/polymer mixed-matrix membranes**

Small molecule Mibridged MOF-802/polymer MMMs were designed for H separation and purification.

[Read More](#)

## **Molecular bridge-mediated ultralow-power gas sensing**

molecular bridge is obtained by fitting and comparing curves at different gas concentrations with the Zim-bovskaya formula to obtain an estimate of the average energy barrier that electrons encounter.

[Read More](#)



## **Oriented molecular bridge at the buried interface**

Herein, a molecular bridge strategy is introduced utilizing sodium 2-cyanoacetate (SZC) additive at the perovskite-buried interface to simultaneously achieve in situ passivation of interfacial

[Read More](#)

## **Dual molecular bridges at perovskite heterointerfaces for efficient**

Holistic construction of molecular bridges We proposed the construction of dual molecular bridges at perovskite heterointerfaces based on the following considerations:  
(1) The

[Read More](#)

## **Bridging the path to multiplexed molecular diagnostics**



Due to the spatial separation achievable using bridge amplification, the approach can overcome problems typically encountered with multiplexed molecular diagnostics, such as the

[Read More](#)

## **Constructing Stabilized Buried Interface via a Robust Molecule Bridge**

A benign buried interface is successfully constructed to enhance the performance and stability of perovskite solar cells via a robust molecular bridge interlayer. Acting as a robust molecular

[Read More](#)

## **Rapid advances enabling high-performance inverted perovskite solar**

Inverted (p-i-n) perovskite solar cells are promising candidates for real-life applications. This Review discusses the current status of this technology, key strategies for stability and

[Read More](#)



## **Regulatory landscape of enhancer-mediated transcriptional activation**

Molecular mechanisms underlying dynamic activator clustering A key question to be addressed regarding the new model for enhancers is the molecular mechanism underlying the

[Read More](#)

## **LRRK2 in Parkinson's disease: upstream regulation and therapeutic**

Dysfunction in LRRK2 enzymatic activities and elevated protein levels are associated with the disease. How is LRRK2 activated, and what downstream molecular and cellular processes does

[Read More](#)



## **Bridging the path to multiplexed molecular diagnostics**

Furthermore, with the demonstration of bridge amplification based on the isothermal recombinase polymerase amplification, the need for complex thermostable chemistry to surface

[Read More](#)

## **EGFR inhibitor-resistant lung cancers exhibit collateral**

Together, these findings demonstrate that diverse models of EGFR inhibitor-resistant NSCLC share the common feature of elevated integrated stress response activity, and that a

[Read More](#)

## **The chemokines CXCL8 and CXCL12: molecular and functional**

CXCL8 in diseases Elevated levels of CXCL8 are found in inflamed tissue and the blood circulation in several inflammatory diseases [21, 71].



[Read More](#)

## **Molecular Electronics: Creating and Bridging Molecular**

Creating and bridging nanogap electrodes for molecular electronics, aiming to explore the charge transport through molecular junctions and develop

[Read More](#)

## **Electronic Communication as a Transferable Property of Molecular Bridges?**

ABSTRACT: Electronic communication through molecular bridges is important for different types of experiments, such as single-molecule conductance, electron transfer, superexchange spin coupling,

[Read More](#)



## Multifunctional Buried Molecule-Bridge for High-Performance

Updated monthly, the Nature Index presents research outputs by institution and country. Use the Nature Index to interrogate publication patterns and to benchmark research performance.

[Read More](#)

## Dual-passivation buried interface molecular bridges for efficient

Herein, a dual-passivation buried interface molecular bridge was constructed between the  $\text{SnO}_2$  and  $\text{CsPbI}_{3-x}\text{Br}_x$  layers by introducing 1-carboxymethyl-3-methylimidazolium chloride (HOOCMIMCl)

[Read More](#)

## Multifunctional TIB molecular bridge for buried interface optimization

Herein, this work introduces 1,3,5-tris (imidazolium)benzene (TIB) as a multifunctional



molecular bridge to simultaneously address interfacial contact and defect-related challenges.

[Read More](#)

## **Dissolvable molecular bridges promoting buried**

Herein, we proposed a dissolvable molecular bridge (DMB) strategy by introducing 4-fluorobenzylphosphonic acid (4F-BPA) on the HTL for synergetic

[Read More](#)

## **Buried interfacial passivation by a multifunctional molecular bridge**

A multifunctional molecular bridge was introduced to passivate the buried interface of doctor-bladed p-i-n perovskite solar cells.

[Read More](#)



## **Multifunctional Buried Molecule-Bridge for**

Herein, a small molecule 4-Bromobenzylphosphonic acid (4Br-BPA) is constructed as a molecule bridge connecting [4- (3,6-dimethyl-9 H -carbazol-9-yl)

[Read More](#)

## **Stable molecular-bridged graphene oxide membrane with bioinspired**

Stable molecular-bridged graphene oxide membrane with bioinspired hydrophilic water inlets for ultrafast molecular separation Boya Wang a b, Cheng Chen a b c, Wei Yu a b, Jiujing Xu a

[Read More](#)

## **An artificial intelligence accelerated ab initio molecular**

This approach can be referred to as machine learning accelerated molecular dynamics



(MLMD) or artificial intelligence accelerated ab initio

[Read More](#)

## **The Inflammatory Bridge Between Type 2 Diabetes and**

Chronic low-grade inflammation is a hallmark of both metabolic and neurodegenerative diseases. In recent years, several studies have highlighted

[Read More](#)

## **Design of Bridge Molecules for High-Efficiency FAPbI**

Here, we propose a technique utilizing bridge molecules to construct a carrier viaduct between perovskite bulk and hole-transporting layers. A molecular bridge configuration combining

[Read More](#)



## A guide to molecular and functional investigations of

A guide to molecular and functional investigations of platelets to bridge basic and clinical sciences Tarun Tyagi, Kanika Jain, Sean X. Gu, Miaoyun Qiu, Vivian W. Gu, Hannah Melchinger,

[Read More](#)

### Contact Us

---

For datasheets, pricing, or custom data center infrastructure solutions, please visit:  
<https://www.zeldaterblanchephotography.co.za>