

What is the dispersion rate of a fiber optic grating

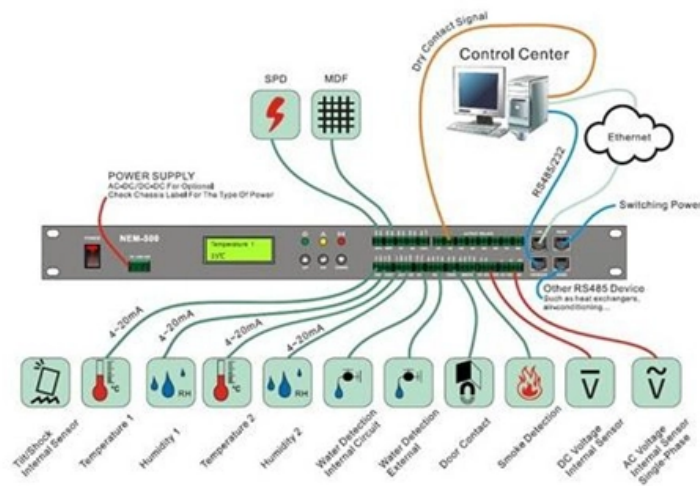



Overview

From this simple picture, the dispersion parameter D_g of a chirped grating of length L_g can be determined by using the relation $T_R = D_g L_g \Delta\lambda$, where T_R is the round-trip time inside the grating and $\Delta\lambda$ is the wavelength spread.



What is the dispersion rate of a fiber optic grating

faker/internet.go at master · pioz/faker · GitHub

Random fake data and struct generator for Go. Contribute to pioz/faker development by creating an account on GitHub.

[Read More](#)

Dispersion Compensation in Optical Fiber

We have analyzed the dispersion compensation using Fiber Bragg Grating at different fiber lengths and different parameters.

[Read More](#)



Spectral and Dispersion Properties of Long Period Fiber

Present work deals with the analytical study of spectral and dispersion properties of long period fiber grating (LPFG) under linear regime.

[Read More](#)

A comprehensive study of dispersion compensation in long haul

Despite Optical fiber transmission systems having several features and advantages, dispersion still remain a main challenge. In this paper we use Acousto Optical Filter (AOF) and Fiber Bragg Grating

[Read More](#)

Dispersion Compensation in Optical Fiber Communication Using Fiber

Abstract - Optical fiber is one of the most important communications media in communication system. Due to its versatile advantages and negligible transmission loss



it is used in high speed data

[Read More](#)

Dispersion Compensation in Optical Fiber Communication using Bragg Grating

The optical fiber used is single mode fiber because has higher data rate and long distance transmission. The fiber Bragg grating is used as the dispersion compensator.

[Read More](#)

Understanding Optical Fiber Dispersion and Its

Delve into the technical aspects of optical fiber dispersion and its compensation methods. This guide provides a comprehensive understanding,

[Read More](#)



Optical Fiber Communications

Optical fiber communications are the technology of transmitting information through optical fibers. Huge data rates are achieved with modern technology.

[Read More](#)

Dispersion Compensation in Optical Fiber

This paper discussed on a simulation of optical transmission system in optical fiber. To achieve the foremost effective performance of communication

[Read More](#)

Fiber Bragg Grating (FBG) Market Trends, Size, Share & Growth

The Fiber Bragg Grating (FBG) Market demonstrated steady growth in sensor and filter manufacturing, driven by optical communication, aerospace, and energy applications. Global FBG



Optical Fiber Communications 101: Key Concepts

The monochromator has a multi-stage optical bandpass filter structure for sharp filtering characteristics to evaluate high-performance, highly functional optical

[Read More](#)

Fundamentals of Grating Knowledge Sharing

Fundamentals of Grating Knowledge Sharing A grating is an optical element composed of numerous equally spaced, parallel slits, typically used for

[Read More](#)

(PDF) Dispersion Compensation in Optical Fiber



There are various types of optical fiber, the Fiber Bragg Grating (FBG) is commonly chosen as important components to compensate the dispersion in

[Read More](#)

Introduction to Diffraction Gratings : Shimadzu

What are Diffraction Gratings A diffraction grating is an optical element that divides (disperses) light composed of lots of different wavelengths (e.g., white light) into

[Read More](#)

Fiber Bragg gratings for dispersion compensation in

This paper presents an overview of fiber Bragg gratings (FBGs) fabrication principles and applications with emphasis on the chirped FBG used for

[Read More](#)



Fiber Bragg Gratings - FBG, index modulation, filters, fiber-optic sensors

A fiber Bragg grating is a structure within the core of an optical fiber with a periodic variation of the refractive index. It acts as a wavelength-selective mirror, reflecting light in a narrow range of

[Read More](#)

Fiber Bragg grating as a sole dispersion compensation unit

This paper presents a comprehensive study of the Gaussian Apodized Fiber Bragg Grating (GA-FBG) as a stand-alone dispersion compensator for a 150 km long optical link.

[Read More](#)

Comprehensive Guide to Optical Fiber Dispersion



Introduction to Optical Fiber Dispersion The digital world is underpinned by the invisible highway of fiber optic cables. Understanding the

[Read More](#)

Dispersion Compensation in Optical Fiber Communication Using Fiber

When a pulse travels through an optical fiber due to dispersion it becomes broadened. The dispersion is proportional to the length of the fiber. If the length is increased the width becomes bulk and the

[Read More](#)

Figure 3 from Interferometric Fiber-Optic Hydrophone System Based

Fig. 3. (a) Received spectrum at different chirp rates. (b) Detailed view around the highest power line. - "Interferometric Fiber-Optic Hydrophone System Based on Linear Frequency Modulation"

[Read More](#)



Understanding Optical Fiber Dispersion and Its

Optical fiber dispersion is a critical aspect of fiber-optic communication systems. This article offers a comprehensive exploration of this

[Read More](#)

High-Speed Fiber-Optic Communication Performance Utilizing Fiber

Abstract--Chromatic dispersion is a significant limitation in optical fiber communication, as it causes pulse broadening, which negatively impacts transmission distance and data rates, both of which are

[Read More](#)

Fiber Lasers - rare-earth doped, high power, narrow



What is a Fiber Laser? Fiber lasers are a special form of solid-state lasers, often having attractive features such as high output power in combination with high

[Read More](#)

Analysis of Dispersion Compensation using Fiber Bragg Grating with

Here, this paper propose and analyze a generalized approach employing the n th root and n th order polynomial chirping profiles within FBGs, examining how the order (n) impacts dispersion in optical

[Read More](#)

Optical Fiber , Optical Fiber Products , Corning

Optical fiber broadband brings together a culture of innovation, quality, and manufacturing excellence to create life-changing products.

[Read More](#)



Implementation of Fiber Bragg Grating for Dispersion Loss

The use of optical fiber in telecommunication systems is primarily due to its compact size, minimal loss, and reduced susceptibility to external interference.

[Read More](#)

Contact Us

For datasheets, pricing, or custom data center infrastructure solutions, please visit:
<https://www.zeldaterblanchephotography.co.za>